

聯成五金(私人)有限公司

LIAN SENG HARDWARE PTE LTD

No.39 Gul Circle Singapore 629574

Circlip (Retainer Clips)

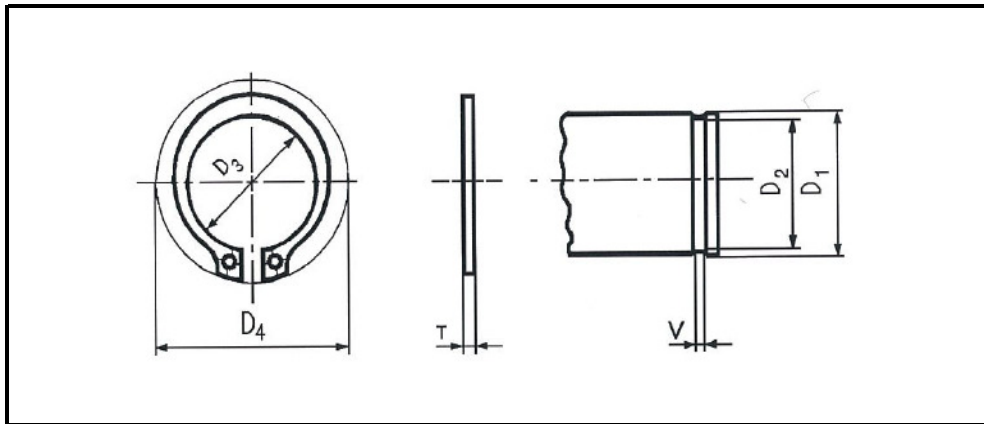

DIN 471/ JIS B 2804

unit: mm

Shaft Dia (D1)	Inner Dia (D3)		Outer Dia (D4)	Thickness (T)	Groove Dia (D2)	Groove Width (V)
	Basic	Tolerance				
3	2.7	+0.04 -0.15	7.0	0.4	2.8	0.5
4	3.7		8.6		3.8	
5	4.7		10.3		4.8	
6	5.6	+0.06 -0.18	11.7	0.7	5.7	0.8
7	6.5		13.5		6.7	
8	7.4		14.7		7.6	
9	8.4	+0.10 -0.36	16.0	1.0	8.6	1.1
10	9.3		17.0		9.6	
11	10.2		18.0		10.5	
12	11.0		19.0		11.5	
13	11.9		20.2		12.4	
14	12.9		21.4		13.4	
15	13.8		22.6		14.3	
16	14.7		23.8		15.2	
17	15.7		25.0		16.2	
18	16.5		26.2		17.0	
19	17.5	+0.13 -0.42	27.2	1.2	18.0	1.3
20	18.5		28.4		19.0	
21	19.5		29.6		20.0	
22	20.5		30.8		21.0	
23	21.5		32.6		22.0	
24	22.2		33.2		22.9	
25	23.2		34.2		23.9	
26	24.2	+0.21 -0.42	35.5	1.5	24.9	1.6
27	24.9		37.2		25.6	
28	25.9		37.9		26.6	
29	26.9		39.1		27.6	
30	27.9		40.5		28.6	
32	29.6		43.0		30.3	
33	30.5		44.4		31.3	
34	31.5	+0.25 -0.5	45.4	1.75	32.3	1.85
35	32.2		46.8		33.0	
36	33.2		47.8		34.0	
37	34.2		49.4		35.0	
38	35.2		50.2		36.0	
40	36.5		52.6		37.5	
42	38.5		55.7		39.5	
45	41.5	+0.39 -0.9	59.1	1.75	42.5	1.85
47	43.5		61.6		44.5	
48	44.5		62.5		45.5	
50	45.8		64.5		47.0	
52	47.8		66.7		49.0	
54	49.8		69.2		51.0	

聯成五金(私人)有限公司

LIAN SENG HARDWARE PTE LTD

No.39 Gul Circle Singapore 629574

Circlip (Retainer Clips)

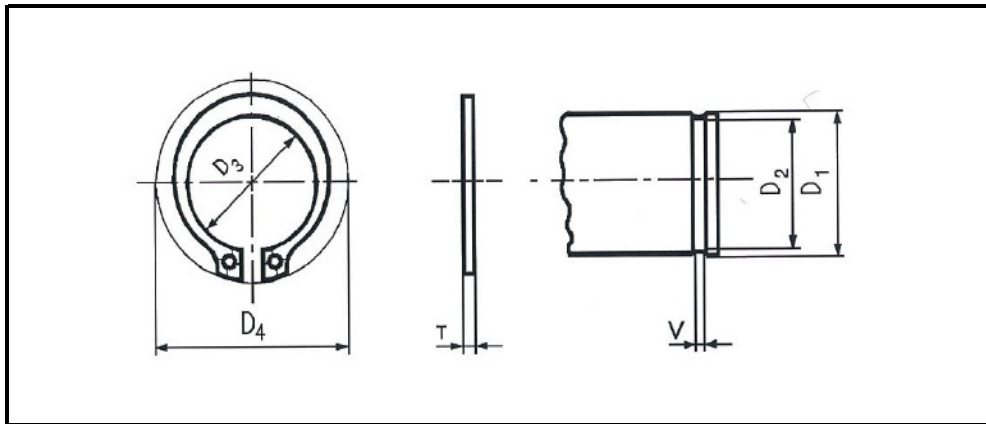

DIN 471/ JIS B 2804

unit: mm

Shaft Dia (D1)	Inner Dia (D3)		Outer Dia (D4)	Thickness (T)	Groove Dia (D2)	Groove Width (V)	
	Basic	Tolerance					
55	50.8	+0.46 -1.1	70.2	2.0	52.0	2.15	
56	51.8		71.6		53.0		
57	52.8		72.6		54.0		
58	53.8		73.6		55.0		
60	55.8		75.6		57.0		
62	57.8		77.8		59.0		
63	58.8		79.0		60.0		
65	60.8		81.4		62.0		
68	63.5		84.8		65.0		
70	65.5		87.0		67.0		
72	67.5	89.2	69.0				
75	70.5	92.7	72.0	2.5	2.65		
78	73.5	96.1	75.0				
80	74.5	98.1	76.5				
82	76.5	100.3	78.5				
85	79.5	100.3	81.5				
88	82.5	106.5	84.5				
90	84.5	108.5	86.5			3.0	3.15
95	89.5	114.8	91.5				
100	94.5	120.2	96.5				
105	98.0	125.8	101.0				
110	103.0	131.2	106.0				
115	108.0	137.3	111.0				
120	113.0	143.1	116.0				
125	118.0	149.0	121.0				
130	123.0	154.4	126.0				
135	128.0	159.8	131.0				
140	133.0	165.2	136.0				
145	138.0	170.6	141.0				
150	142.0	177.3	145.0	4.0	4.15		
155	146.0	182.3	150.0				
160	151.0	188.0	155.0				
165	155.5	193.4	160.0				
170	160.5	198.4	165.0				
175	165.5	203.4	170.0				
180	170.5	210.0	175.0				
185	175.5	215.0	180.0				
190	180.5	220.0	185.0				
195	185.5	225.0	190.0				
200	190.5	230.0	195.0				
210	198.0	240.0	204.0	+0.72 -1.7			
220	208.0	250.0	214.0				
230	218.0	260.0	224.0				

聯成五金(私人)有限公司

LIAN SENG HARDWARE PTE LTD

No.39 Gul Circle Singapore 629574

Circlip (Retainer Clips)

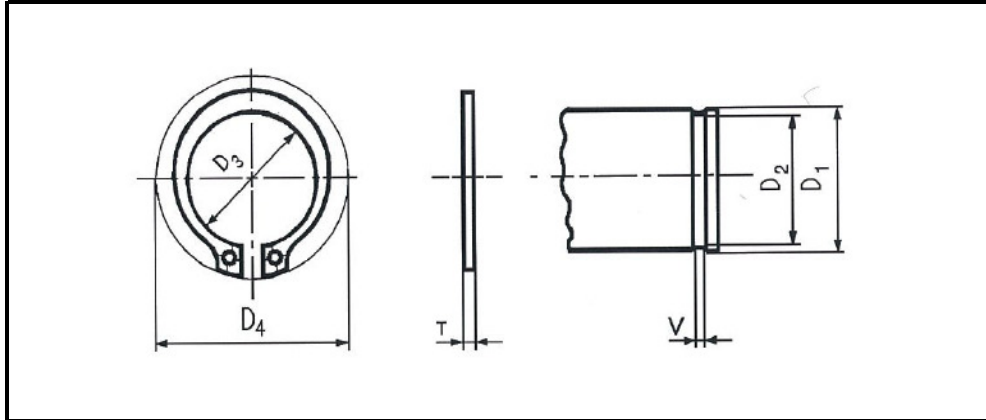

DIN 471/ JIS B 2804

unit: mm

Shaft Dia (D1)	Inner Dia (D3)		Outer Dia (D4)	Thickness (T)	Groove Dia (D2)	Groove Width (V)
	Basic	Tolerance				
240	228.0		270.0	5.0	234.0	5.15
250	238.0		280.0		244.0	
260	245.0		294.0		252.0	
270	255.0		304.0		262.0	
280	265.0	+0.81	314.0		272.0	
290	275.0	-2.0	324.0		282.0	
300	285.0		334.0		292.0	